

FLiP-WX Wiring Diagram

Parallax Propeller FLiP Module
#32123
40-pin 0.1" pitch, 600 mil

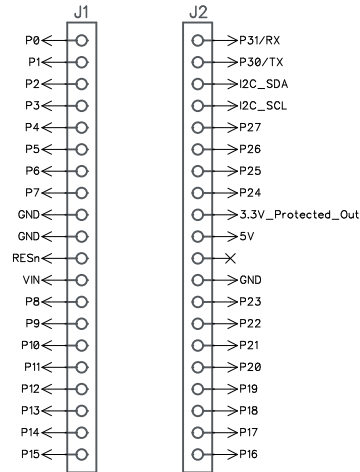

Parallax WX WiFi Module SIP
#32420S
10-pin 0.1" pitch

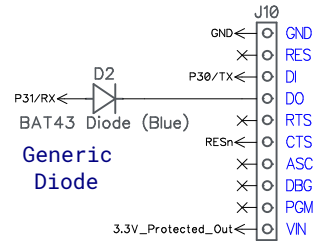

Parallax Reset Switch
#400-10022
4-pin 0.2" pitch, 300 mil



Information:

The BAT43 Diode will allow the Propeller FLiP module to be programmed (and use terminal) via either the USB port or WiFi port, connected at the same time.

If the Propeller FLiP will be powered by VIN, or with a Powerbank connected to USB, then the Diode is optional.

Parallax Inc.
599 Menlo Drive
Rocklin, CA 95765

(916) 624-8333
<https://www.parallax.com/>

Propeller FLiP-WX Wiring Diagram

Copyright 2024 Parallax Incorporated. All Rights Reserved.

Revision: A

Last Update: 09 Dec 2024